

Cree® XLamp® XB-D LEDs



INTRODUCTION

This application note applies to XLamp XB-D LEDs which have order codes in the following format.

XBDxxx-xx-xxxx-xxxxxxxxxx

This application note explains how XLamp XB-D LEDs and assemblies containing these LEDs should be handled during manufacturing. Please read the entire document to understand how to properly handle XLamp XB-D LEDs.

TABLE OF CONTENTS

Handling XLamp XB-D LEDs	2
Circuit Board Preparation & Layouts	4
Case Temperature (T _s) Measurement Point	4
Notes on Soldering XLamp XB-D LEDs	5
Moisture Sensitivity	6
XLamp XB-D LED Reflow Soldering Characteristics ..	7
Chemicals & Conformal Coatings	8
Assembly Storage & Handling.....	9
Tape and Reel - XB-D LEDs	10
Packaging & Labels	11

HANDLING XLAMP XB-D LEDs

Manual Handling

Use tweezers to grab XLamp XB-D LEDs at the base. Do not touch the lens with the tweezers. Do not touch the lens with fingers. Do not push on the lens.

Do not apply more than 1000 g of shear force onto the lens. Excessive force on the lens could damage the LED.

CORRECT

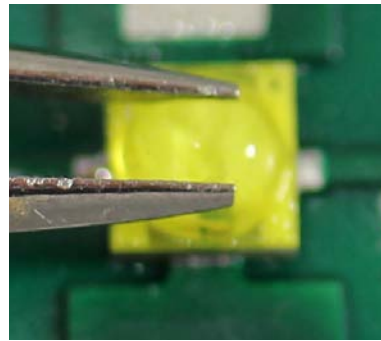
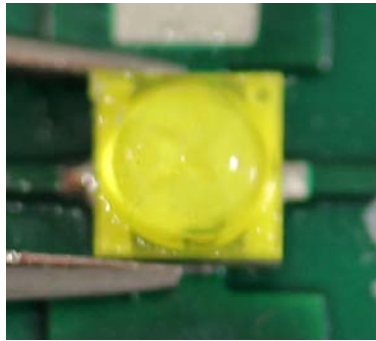

WRONG

Cree recommends the following at all times when handling XLamp XB-D LEDs or assemblies containing these LEDs:

- Avoid putting excessive mechanical stress on the LED lens.
- Never touch the optical surface with fingers or sharp objects. The LED lens surface could be soiled or damaged, which would affect the optical performance of the LED.

Whenever possible, Cree recommends the use of a pick & place tool to remove XLamp XB-D LEDs from the factory tape & reel packaging.

Pick & Place Nozzle

For pick and place nozzles coming into contact with silicone-covered LED components, Cree recommends nozzles be constructed of non-metallic materials. Cree and several of Cree’s customers have had good success using nozzles fabricated from Teflon or from 90d urethane. The following pick & place tool is specific to the XB Family LEDs.

All dimensions in mm.

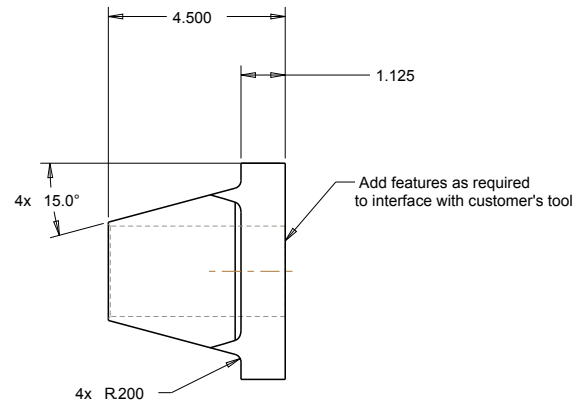
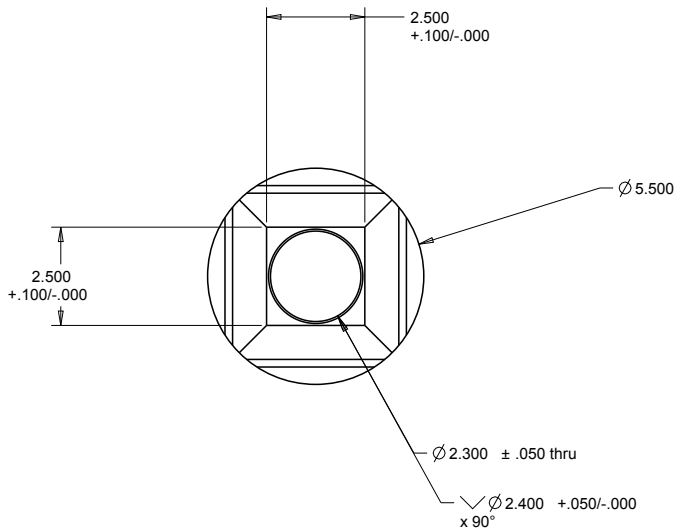

CIRCUIT BOARD PREPARATION & LAYOUTS

Printed circuit boards (PCBs) should be prepared and/or cleaned according to the manufacturer’s specifications before placing or soldering XLamp XB-D LEDs onto the PCB.

The diagram below shows the recommended PCB solder pad layout for XLamp XB-D LEDs.

All dimensions in mm.

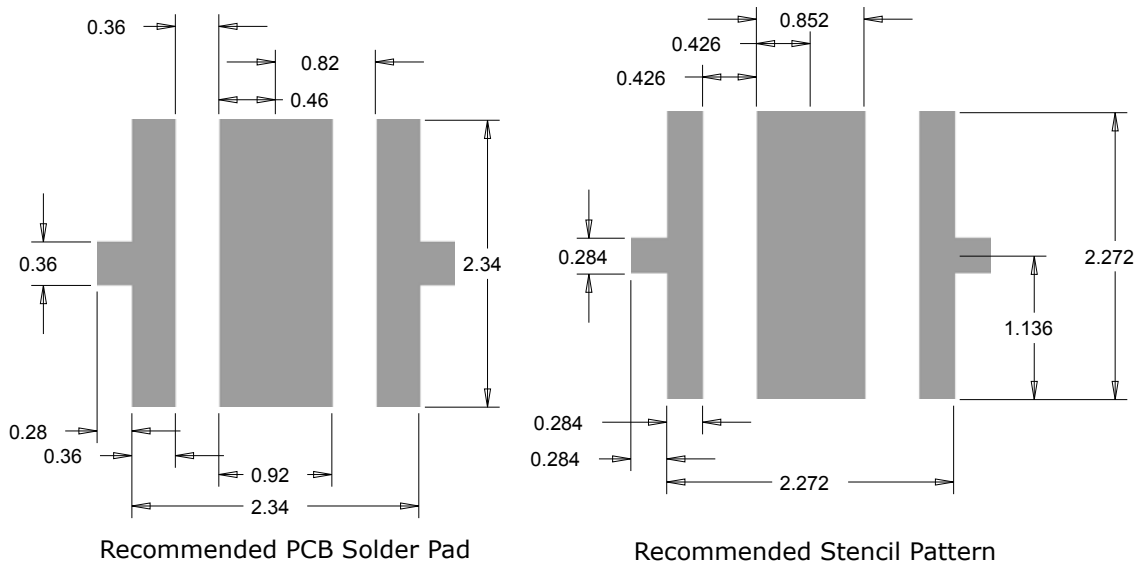

CASE TEMPERATURE (T_s) MEASUREMENT POINT

XLamp XB-D LED case temperature (T_s) should be measured on the PCB surface, as close to the LED’s thermal pad as possible. This measurement point is shown in the picture below.

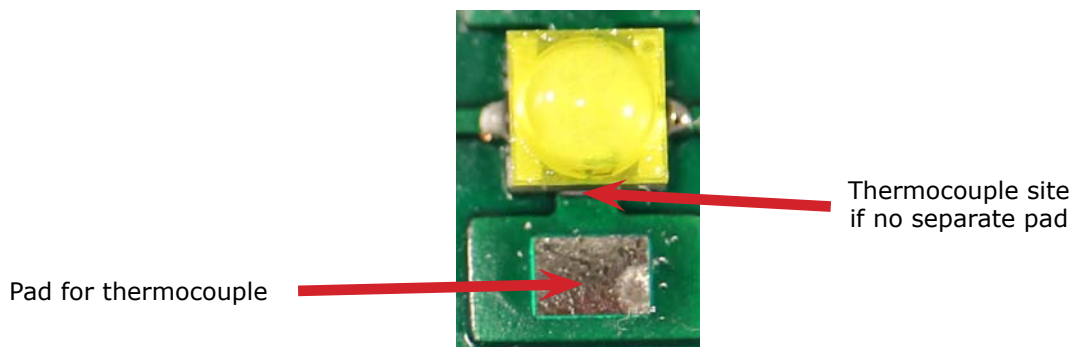

It is not required to use a solder footprint for the thermal pad that is larger than the XLamp XB-D LED itself. In testing, Cree has found such a solder pad to have insignificant impact on the resulting T_s measurement.

NOTES ON SOLDERING XLAMP XB-D LEDs

XLamp XB-D LEDs are designed to be reflow soldered to a PCB. Reflow soldering may be done by a reflow oven or by placing the PCB on a hotplate and following the reflow soldering profile listed on the previous page.

Do not wave solder XLamp XB-D LEDs. Do not hand solder XLamp XB-D LEDs.

✓
CORRECT



✓
CORRECT



✗
WRONG

Solder Paste Type

Cree strongly recommends using “no clean” solder paste with XLamp XB-D LEDs so that cleaning the PCB after reflow soldering is not required. Cree uses the following solder paste internally.

Indium Corporation of America® Part number 82676

- Sn62/Pb36/Ag2 composition
- Flux: NC-SMQ92J

Cree recommends the following solder paste compositions: SnPbAg, SnAgCu and SnAg.

Solder Paste Thickness

The choice of solder and the application method will dictate the specific amount of solder. For the most consistent results, an automated dispensing system or a solder stencil printer is recommended. Cree has seen positive results using solder thickness that results in a 3-mil (75-µm) bond line.

✓
CORRECT



✗
WRONG

After Soldering

After soldering, allow XLamp XB-D LEDs to return to room temperature before subsequent handling. Handling of the device, especially around the lens, before cooling could result in damage to the LED.

Cree recommends verifying the solder process by checking the consistency of the solder bond of several trial PCBs after reflow. This can be done by X-ray or by shearing selected devices from the circuit board. The solder should appear completely re-flown (no solder grains evident). The solder areas should show minimum evidence of voids on the backside of the package and the PCB.

Cleaning PCBs After Soldering

Cree recommends using “no clean” solder paste so that flux cleaning is not necessary after reflow soldering. If PCB cleaning is necessary, Cree recommends the use of isopropyl alcohol (IPA).

Do not use ultrasonic cleaning.

MOISTURE SENSITIVITY

In testing, Cree has found XLamp XB-D LEDs to have unlimited floor life in conditions ≤ 30 °C / 85% relative humidity (RH). However, Cree recommends keeping XLamp LEDs in their sealed moisture-barrier packaging until immediately prior to use. Cree also recommends returning any unused LEDs to the resealable moisture-barrier bag and closing the bag immediately after use. Moisture testing included a 168-hour soak at 85 °C / 85% RH followed by 3 reflow cycles, with visual and electrical inspections at each stage.

XLAMP XB-D LED REFLOW SOLDERING CHARACTERISTICS

In testing, Cree has found XLamp XB-D LEDs to be compatible with JEDEC J-STD-020C, using the parameters listed below. As a general guideline, Cree recommends that users follow the recommended soldering profile provided by the manufacturer of solder paste used.

Note that this general guideline is offered as a starting point and may require adjustment for certain PCB designs and configurations of reflow soldering equipment.

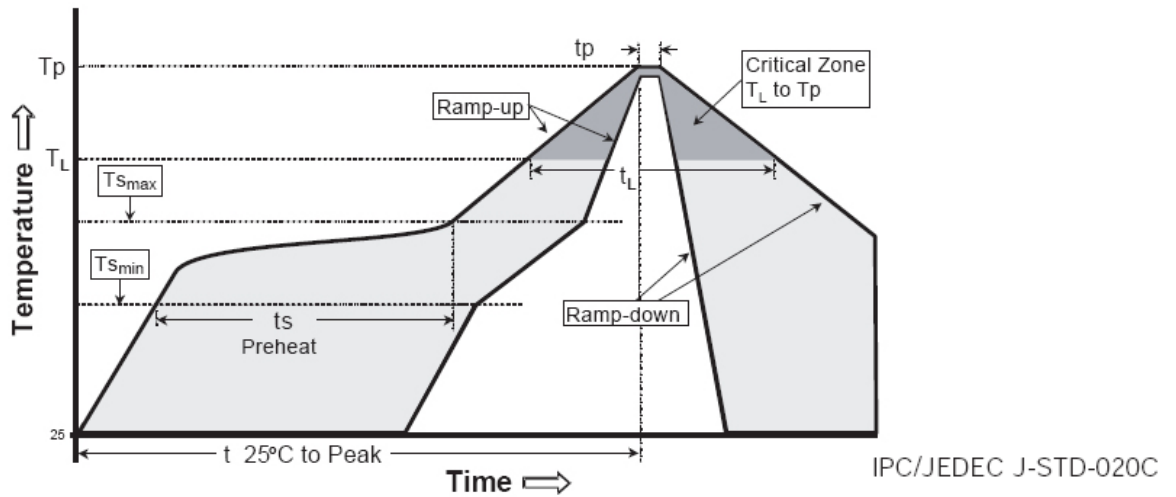

Profile Feature	Lead-Based Solder	Lead-Free Solder
Average Ramp-Up Rate ($T_{s_{max}}$ to T_p)	3 °C/second max.	3 °C/second max.
Preheat: Temperature Min ($T_{s_{min}}$)	100 °C	150 °C
Preheat: Temperature Max ($T_{s_{max}}$)	150 °C	200 °C
Preheat: Time ($t_{s_{min}}$ to $t_{s_{max}}$)	60-120 seconds	60-180 seconds
Time Maintained Above: Temperature (T_l)	183 °C	217 °C
Time Maintained Above: Time (t_l)	60-150 seconds	60-150 seconds
Peak/Classification Temperature (T_p)	215 °C	260 °C
Time Within 5 °C of Actual Peak Temperature (t_p)	10-30 seconds	20-40 seconds
Ramp-Down Rate	6 °C/second max.	6 °C/second max.
Time 25 °C to Peak Temperature	6 minutes max.	8 minutes max.

Note: All temperatures refer to topside of the package, measured on the package body surface.

CHEMICALS & CONFORMAL COATINGS

Below are representative lists of chemicals and materials to be used or avoided in LED manufacturing activities. For a complete and current list of recommended chemicals, conformal coatings and harmful chemicals consult Cree's Chemical Compatibility Application Note (www.cree.com/products/pdf/XLamp_Chemical_Comp.pdf). The video at www.youtube.com/watch?v=t24bf9D_1SA illustrates the process Cree has developed for testing the compatibility of chemicals and materials with LEDs. You should also consult your regional Cree Field Applications Engineer.

Recommended Cleaning Solutions

Cree has found the following chemicals to be safe to use with XLamp XB-D LEDs.

- Water
- Isopropyl alcohol (IPA)

Chemicals Tested as Harmful

In general, subject to the specifics in Cree's Chemical Compatibility Application Note, Cree has found certain chemicals to be harmful to XLamp XB-D LEDs. Cree recommends not using these chemicals anywhere in an LED system containing XLamp XB-D LEDs. The fumes from even small amounts of the chemicals may damage the LEDs.

- Chemicals that might outgas aromatic hydrocarbons (e.g., toluene, benzene, xylene)
- Methyl acetate or ethyl acetate (i.e., nail polish remover)
- Cyanoacrylates (i.e., "Superglue")
- Glycol ethers (including Radio Shack® Precision Electronics Cleaner - dipropylene glycol monomethyl ether)
- Formaldehyde or butadiene (including Ashland PLIOBOND® adhesive)

Potential of Silver Tarnishing

XLamp XB-D LEDs contain silver plated parts that may tarnish (turn black) over time when exposed to oxidizing substances such as sulfur, chlorine, or other halogen compounds. Oxidation of the leads can reduce the ability to make a good solder connection and affect the light output of the LED. Exposure to oxidizing substances can come from materials used near the LED during manufacturing or from the air around the LEDs during storage.

To reduce the potential of tarnishing for XLamp XB-D LEDs, Cree recommends that customers minimize exposure of the LEDs to oxidizing substances at all times, including dry box storage, manufacturing and product testing. Potential sources of oxidizing substances include paper, air filters, some cleaning chemicals, cardboard boxes and rubber anti-static mats.

ASSEMBLY STORAGE & HANDLING

Do not stack PCBs or assemblies containing XLamp XB-D LEDs so that anything rests on the LED lens. Force applied to the LED lens may result in the lens being knocked off. PCBs or assemblies containing XLamp XB-D LEDs should be stacked in a way to allow at least 2 cm clearance above the LED lens.

Do not use bubble wrap directly on top of XLamp XB-D LEDs. Force from the bubble wrap can potentially damage the LED.

✓
CORRECT

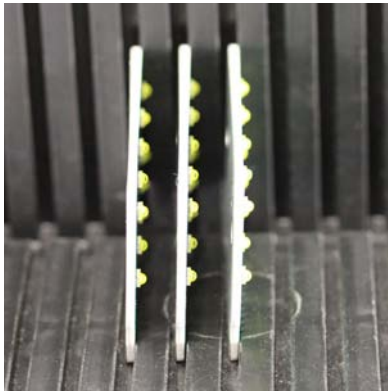

✓
CORRECT

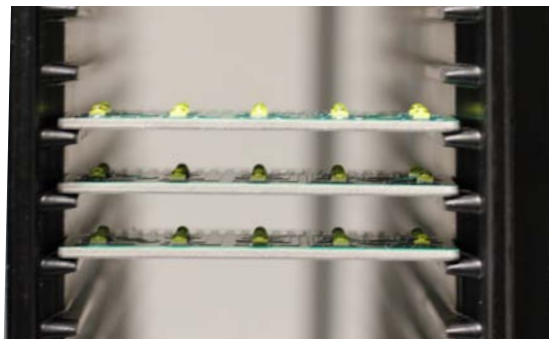

✗
WRONG

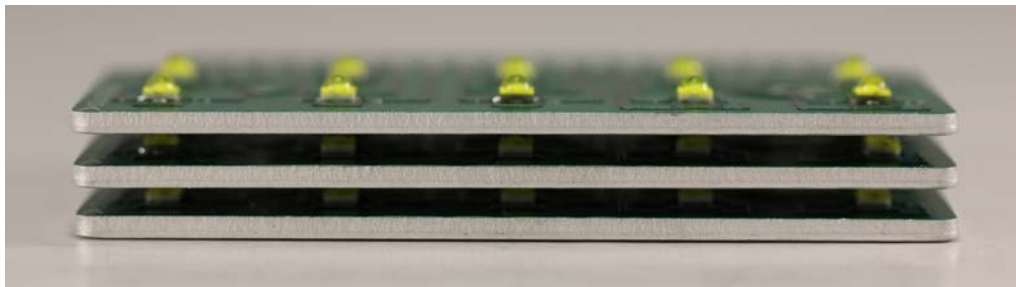

TAPE AND REEL - XB-D LEDs

All Cree carrier tapes conform to EIA-481D, Automated Component Handling Systems Standard.

All dimensions in mm.

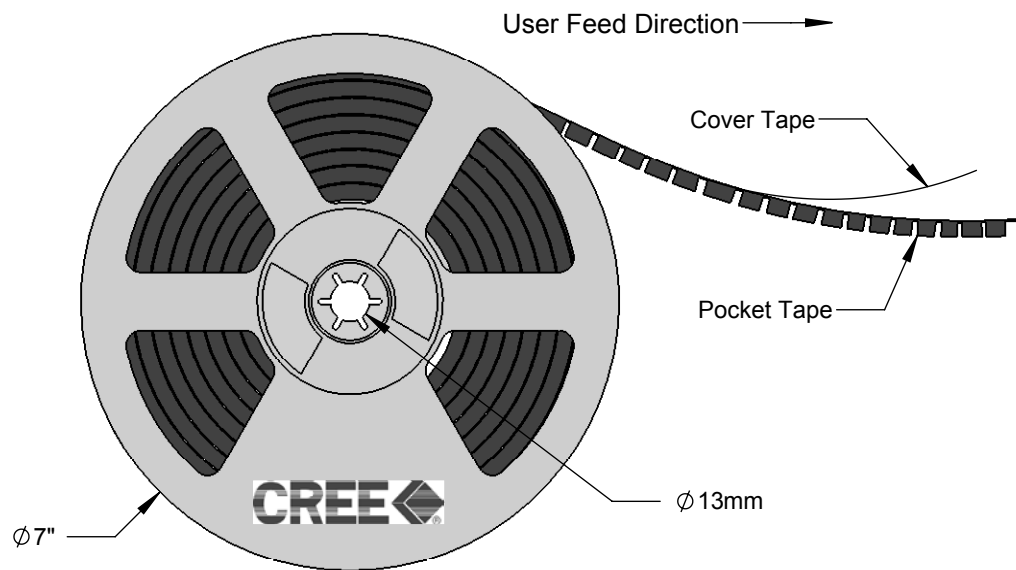
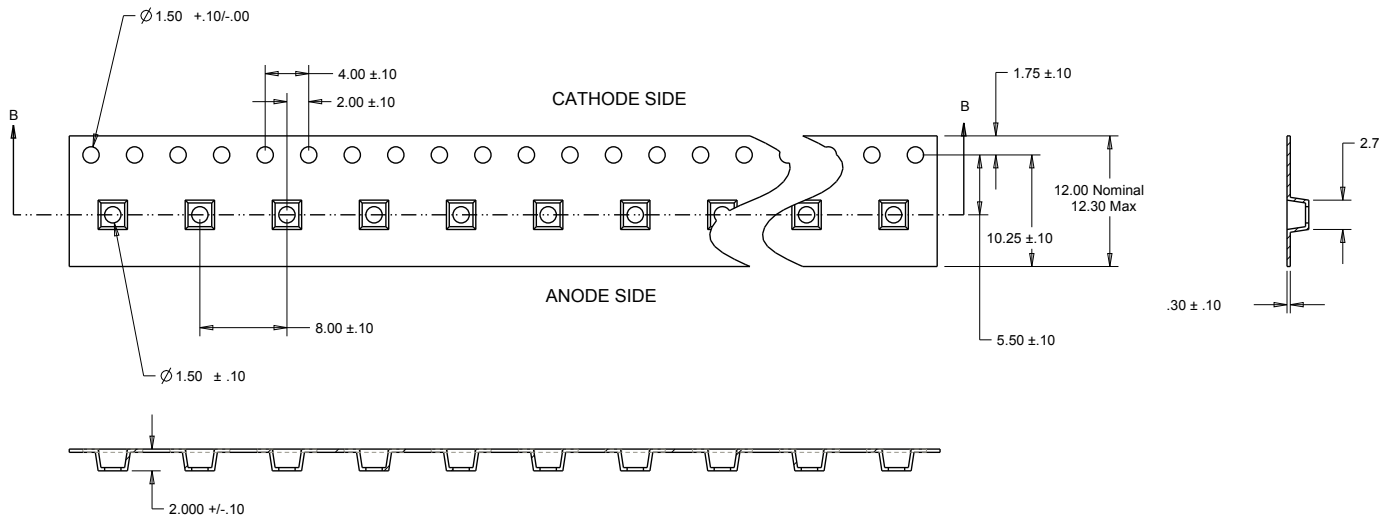

PACKAGING & LABELS

The diagrams below show the packaging and labels Cree will use to ship XLamp XB-D LEDs. XLamp XB-D LEDs are shipped in tape loaded on a reel. Each moisture barrier bag contains only one reel. Each box may contain multiple reels.

