

# APPLICATION NOTE

## Mounting Approaches for RF Products Using the 780019 Package Type

### INTRODUCTION

The objective of this application note is to provide users of Cree RF products using the 780019 package type with a guide on various mounting approaches. It explains the several methods of creating the electrical connection from the input and output traces on the 780019 package to the PCB. This guide does not include all possible approaches. It discusses the use of compression strips, adding interconnect leads, gap welding, and wire bonding. The CMPA2560025F product is the 780019 package type example used in this application note.

Next level assembly electrical and mechanical performance requirements, packaging materials and assembly processes vary. As such, Cree recommends users fully characterize the interconnected assembly from both a performance and process perspective before launching into full scale production.

### USING COMPRESSION STRIPS AND CLAMPS TO CONNECT CMPA2560025F MMIC POWER AMPLIFIER TO CMPA2560025F-TB TEST FIXTURE

Compression strip connectors and clamps are an alternative interconnect method to wire bonds and gap welds. The compression strip is comprised of a silicone elastomeric core with conductor wires on one side. The clamp is made of Delrin plastic. When bolted down to the baseplate, the clamp compresses against the compression strip and the conductor wires in turn make electrical contact with the pads on both the MMIC Power Amplifier device and pads on the next level assembly substrate.

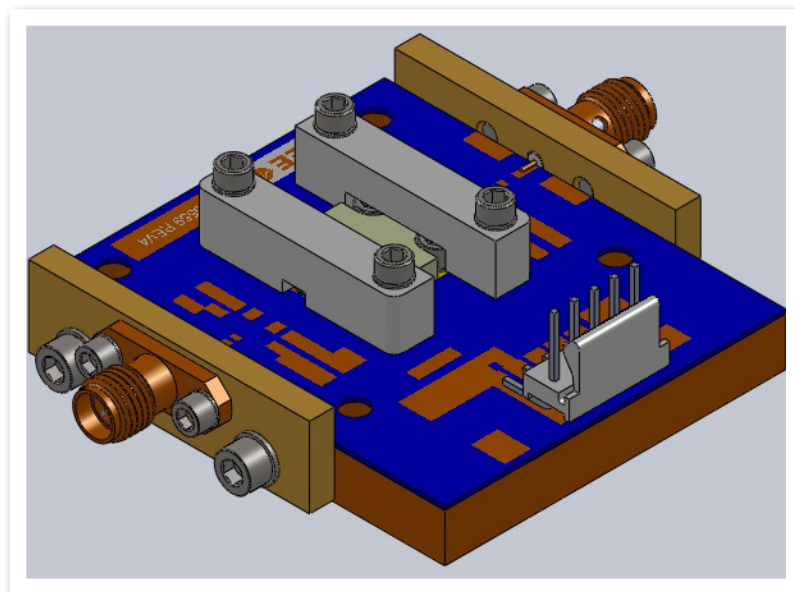

Figure 1. CMPA2560025F MMIC Power Amplifier and CMPA2560025F-TB Test Fixture

## PROCEDURE TO INSTALL CMPA2560025F MMIC POWER AMPLIFIER INTO TEST FIXTURE

Approximately center the thermal interfaced material in the CMPA2560025F-TB test fixture pocket. Carefully place CMPA2560025F MMIC Power Amplifier package on top of Indium foil. Install 4x #2-56 x 3/16" screws and torque to 40 in-oz. Assemble compression strips and clamps per Figure 2. Cree recommends installing a thermal interface material between the CMPA2560025F MMIC power amplifier and test fixture or next level assembly heat sink. Recommended thermal interface materials:

- a. Indium Corp. part number RECTANGLEPI-19997X (0.004" thick Heat Spring Indium foil; 52% Indium, 48% Tin)
- b. Indium Corp. part number IND3HSD003 (2" x 2" x 0.003" thick with 0.0002" aluminum cladding on one side; trim to 0.300" x 0.500")
- c. Dow Corning 340 Heat Sink Compound

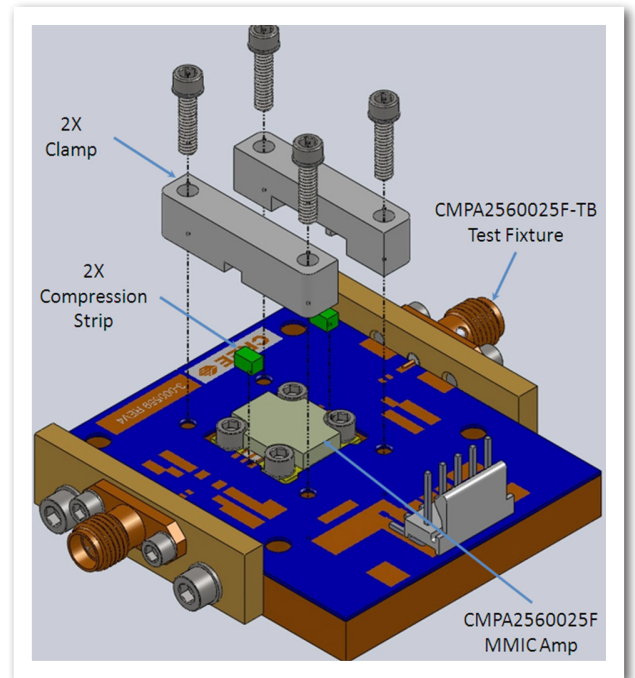

Figure 2. Exploded View of CMPA2560025F MMIC Power Amplifier and CMPA2560025F-TB Test Fixture

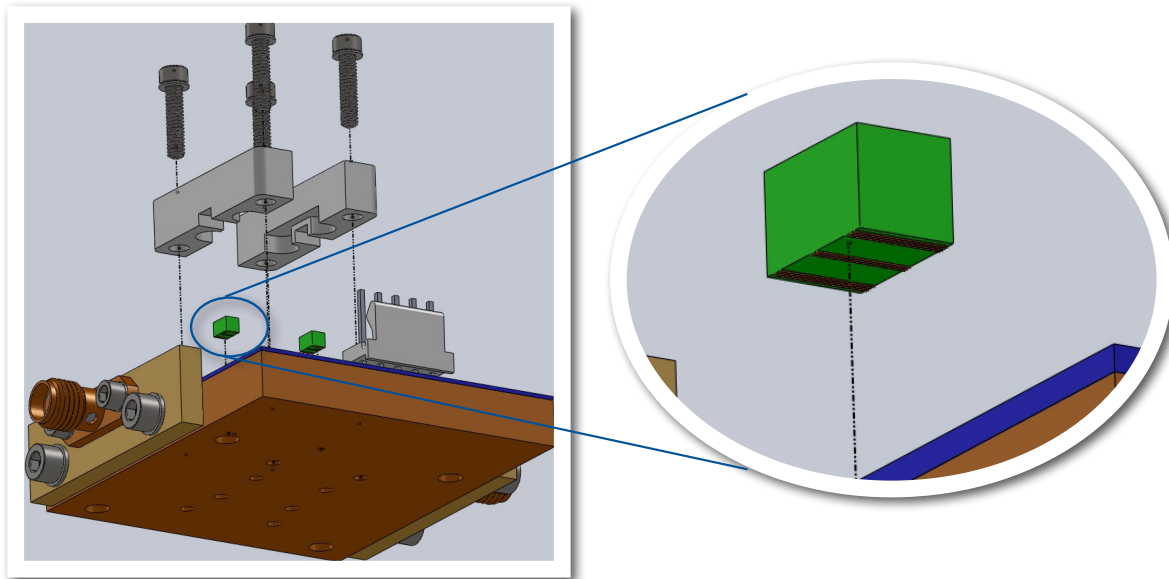

Figure 3. Exploded View Showing Orientation of Compression Strips to Test Fixture

Orient compression strips such that the conductor lines face down to the test fixture and are aligned with the traces on the MMIC Power Amplifier package and test fixture. See Figure 3.

## PROCEDURE TO INSTALL COMPRESSION STRIPS AND CLAMPS

Carefully compress the elastomeric end of the compression strip and insert into the notch in the clamp. NOTE: the compression strip is fragile and fits snugly into the notch in the clamp so exercise care during installation. Cree recommends using fine tip

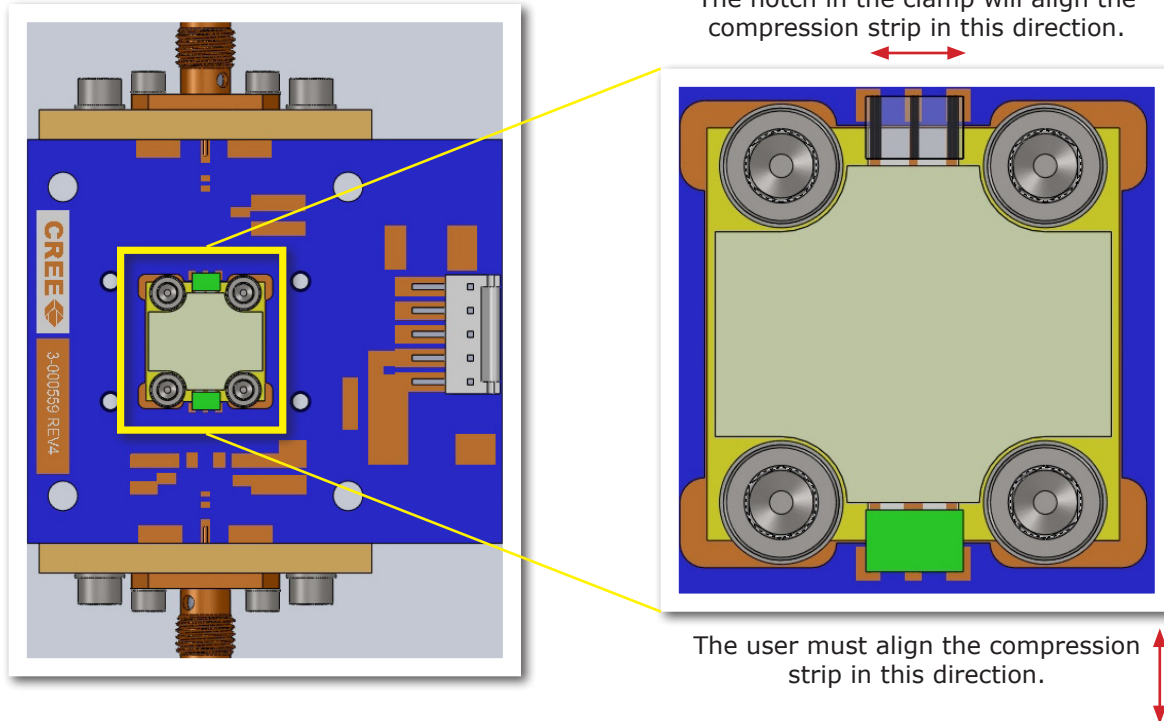

Figure 4. Top View Showing Compression Strip Approximately Centered over Test Fixture and MMIC Amp Traces (Clamps Hidden for Clarity)

tweezers when handling the compression strip. Adjust the position of the compression strip in the clamp such that it is biased flush to one side of the clamp. Next, orient the clamp such that the compression strip is biased closer to the MMIC power amplifier. This will approximately align the compression strip over the device and PCB pads per Figure 4. Install 2X #2-56 x 0.375" long screws to finger tight. Due to assembly tolerances between the screw and clamp holes, small adjustments to the clamp position may be required to fully align the conductors on the compression strip to the pads per Figure 4. To ensure that the conductors on the compression strip make coplanar contact with the device and PCB pads, alternate tightening of each screw one turn at a time to achieve a torque of 40 in-oz.

Part Number	Description	Qty
CMPA2560025F	GaN MMIC	1
CMPA2560025F-TB	Test Board	1
-	Indium Foil	1
ZFLAT-036	Z-Axis Connector	2
4-001594	Clamp	2
-	Screw, #2-56 x 3/16" long	4
-	Screw, #2-56 x 3/8" long	4

## WIRE BONDING THE CMPA2560025F MMIC POWER AMPLIFIER

Wire bonding is the preferred interconnection method to the next level assembly. When executed properly, wire bonding produces strong and reliable bonds and is generally considered to be the most cost effective interconnection method. Cleanliness of the bond surfaces is essential. Devices as received from Cree's original packaging should not require additional cleaning if handled properly and stored in a clean room environment.

Gold wire bonds and gold metallization on the pads at the next level assembly are recommended to ensure galvanic compatibility as well as a robust long term electrical and mechanical connection. Do not bond gold wires to tin solder coated pads.

Cree recommends using two 0.001" or 0.002" diameter gold wires for connection. When using 0.002" diameter wires, a minimum of two wires per pad is recommended. Figure 5 depicts wedge bonds connecting the gold metallized pads on the MMIC Amplifier device to gold metallized pads on the next level assembly substrate.

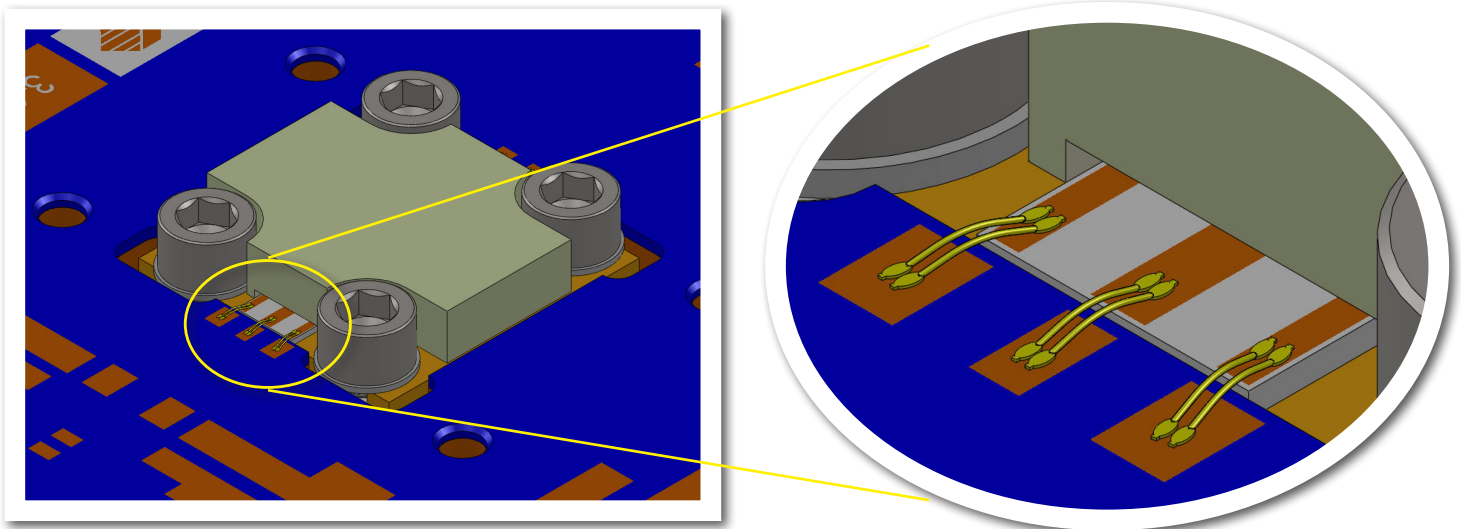

Figure 5. CMA2560025F MMIC Power Amplifier Wire Bonded at Next Level Assembly

## GAP WELDING THE CMPA2560025F MMIC POWER AMPLIFIER

The CMPA2560025F MMIC Power Amplifier may also be gap welded to the next level assembly. Gap welding fuses the metal ribbon material to bond pad metal using pressure and heat. The amount of pressure and heat required for gap welding exceeds that required for wire bonding, thereby yielding an increased risk of damage to electrical components being welded. As a general rule, the user should not specify gap welding where the application will allow for wire bonding. Gap welded interconnect ribbons are illustrated in Figure 6.

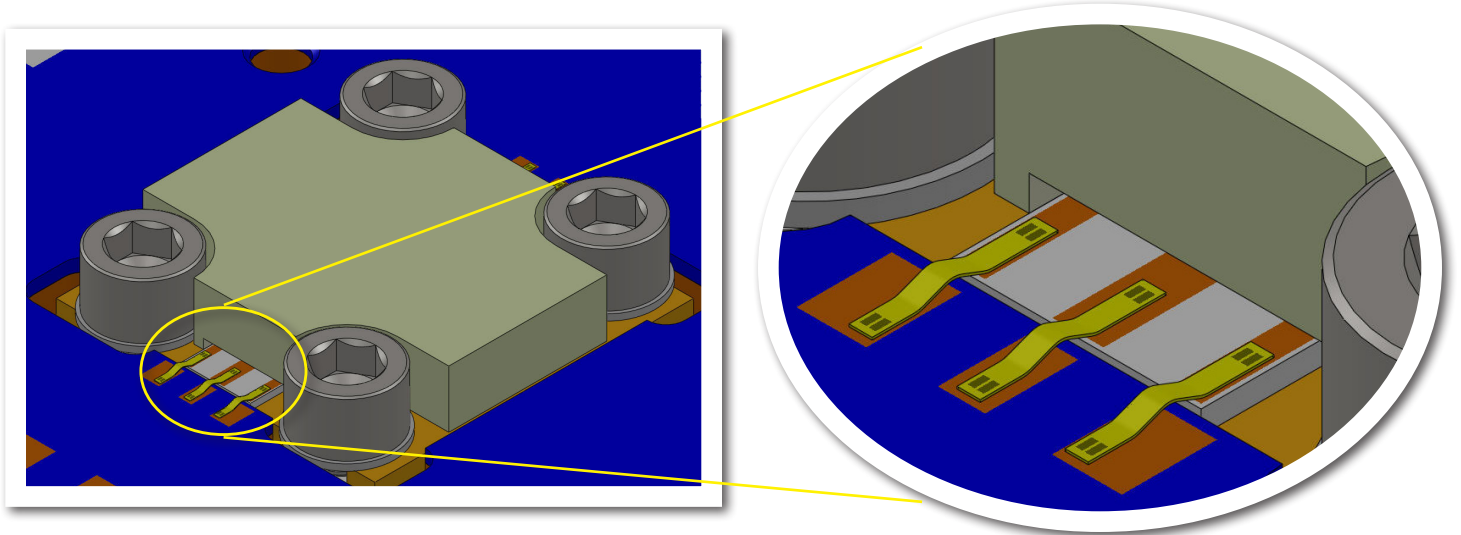

Figure 6. Illustration of CMPA2560025F MMIC Power Amplifier Gap Welded at Next Level Assembly

If the substrate pads on the next level assembly are gold plated, Cree recommends using gold ribbon. Gold ribbon ensures long term galvanic compatibility to the gold pads on the CMPA2560025F. Silver ribbon is recommended for applications where the substrate pads on the next level assembly are tin or tin/lead solder coated or plated.

MMIC Power Amplifier pad size dictates the maximum width of the gap weld ribbon to be 0.010". Ribbon thickness will vary based on the current flow required and the user's gap weld process standards.

## CPA2560025F MMIC POWER AMPLIFIER WITH GAP WELDED INTERCONNECT LEADS

As an alternate approach, for customers that do not have the ability to gap weld ribbon interconnects to the CPA2560025F MMIC Power Amplifier traces, there are contract manufacturers offering lead-attach as a service. One such company is SMT Manufacturing Group.

[www.smt-llc.com](http://www.smt-llc.com) SMT Manufacturing Group will bond 0.010" wide by 0.001" thick gold plated copper ribbon to the CPA2560025F pads as illustrated in Figure 7. Greater than 0.100" of excess ribbon length is supplied for the next level assembly per Figure 8.

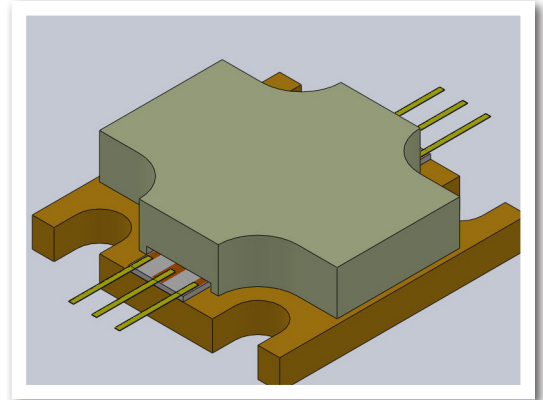

Figure 7. CPA2560025F MMIC Power Amplifier with Gap Welded Ribbon Interconnect Leads

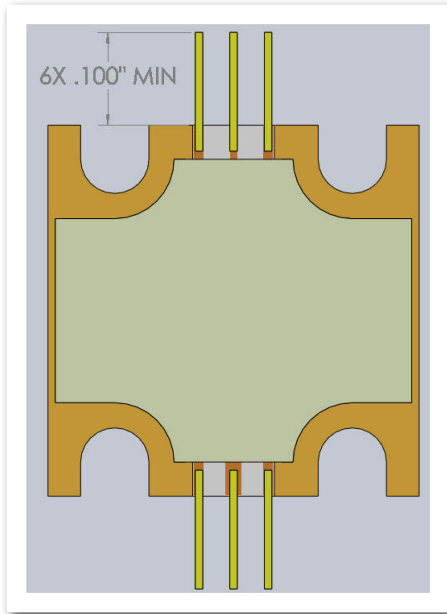

Figure 8. Excess Interconnect Supplied for Next Assembly

Trim the leads as required, apply stress relief and solder the end of the leads to the next level assembly substrate as illustrated in Figure 9.

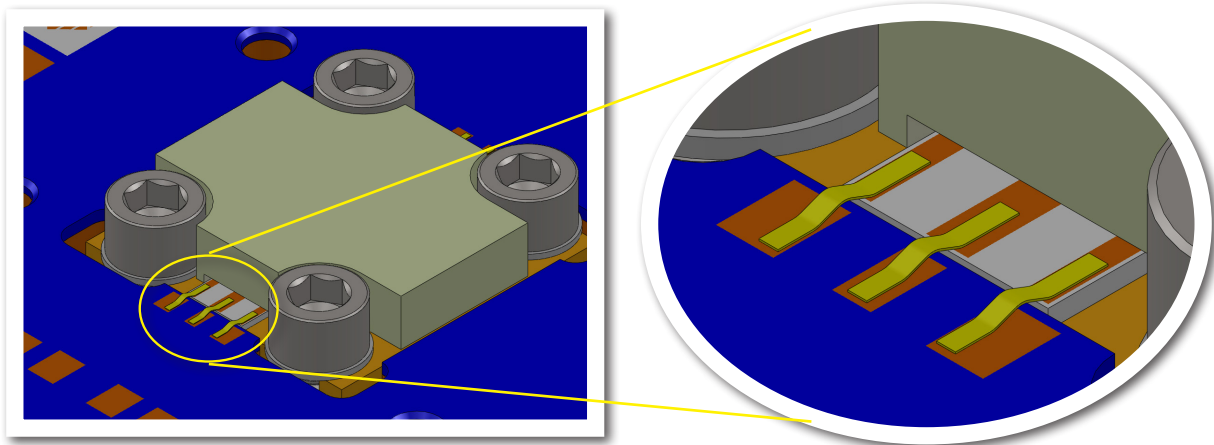

Figure 9. Illustration of CPA2560025F Installed at Next Level Assembly



## CMPA2560025F INSTALLATION ELECTRICAL VERIFICATION

To ensure proper alignment of the strips, it is important to perform electrical tests. This simple test will verify proper installation and a properly functioning amplifier.

Connect the DC cable as per the 'Turn On Instructions' included in the kit. Apply  $0.1 V_{DC}$  to the drain wire and  $0.0 V_{DC}$  to the gate wire. Proper operation will result in  $\sim 200\text{-}300 \text{ mA } I_D$ . Apply  $-5.0 V_{DC}$  to the gate wire, the  $I_D$  should reduce to zero. (pinch-off). If you can verify the currents above, then you have a properly installed the MMIC amplifier.